

# ECO PHYSICS CLD 811

## Application examples

- Emissions Test Benches
- Catalyst Development
- Engine Test Cells
- Car Production
- Exhaust Analysis

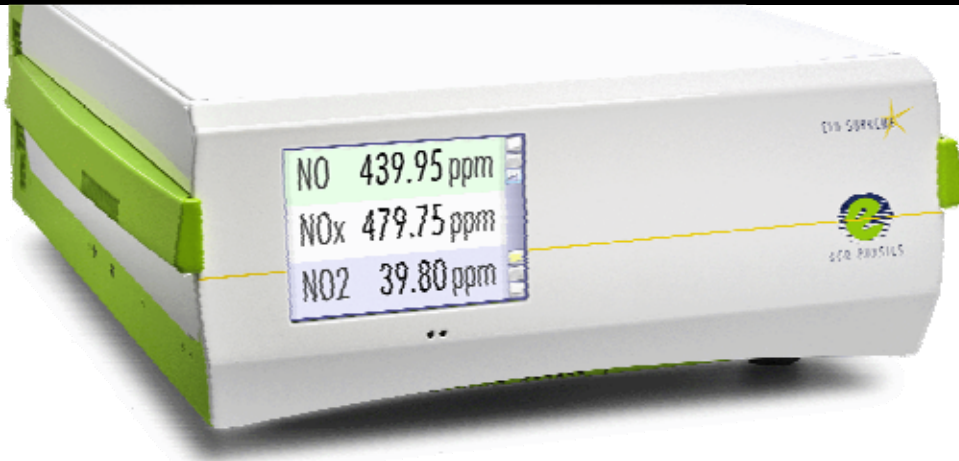

The CLD 811 nitrogen oxide analyzer is unique in its performance with a colorful touch screen display enabling easy and flexible operation. It allows the simultaneous measurement of NO, NO<sub>2</sub> and NO<sub>x</sub> concentrations in raw exhaust of several thousand ppm down to a ppb!



Monitoring of exhaust

### When decimals are decisive.

The CLD 811 fulfills the requirements of the automotive industry when it comes to monitor reproducible and reliable NO<sub>x</sub> data. With its heated inlet and its automated pressure control the analyzer can handle rough samples, such as raw exhaust gas. Beyond with the detection limit of 1 ppb bag samples may be analyzed with the same instrument.

### Compact and modular design.

The CLD 811 is the most compact unit of its class. Thanks to the totally modular layout, this analyzer is designed for your system or may be placed nearby your sampling point. Thus, it will make your most indispensable measurement tool for you for a multitude of applications.

- Compact design without any additional space required
- Minimized CO<sub>2</sub> and H<sub>2</sub>O quenching
- Four freely selectable measurement ranges
- Operation and control via touch screen or remote personal computer



Clearly structured graphic touch screen display informs the user about real-time data and instrument status

This is the result of an extended range capability designed into this state of the art NO<sub>x</sub> monitor. Its stability, reproducibility and reliability are representing the name ECO PHYSICS at its best.

### User friendliness.

Ease of use has top priority. The analyzer powers up automatically and reaches the continuous measurement mode without any user interaction. Of course, if needed the user may choose individual sequences and select from the predefined settings in a simple menu.

### Meeting tough demands.

The legislators push the environmental laws, taking giant strides. In the automotive industry the measurement of hot, raw exhaust gases is mandated by law – EURO 6 or EPA 2014 – and it is now only a question of time before this is extended to other areas, such as the manufacture of off-road engines. Therefore forward-looking suppliers of drive components verify the nitrogen oxide emissions of their products for the sake of both: the environment and quality. Only the best performing benches will lead to truly optimized engines. And many know how to achieve it: with the most reliable measuring instruments from ECO PHYSICS!

# CLD 811

## Specifications

<i>Measuring ranges</i>	four freely selectable ranges from 1–10'000 ppm	<i>Display</i>	7" color, touch screen
<i>Min. detectable concentration</i>	1 ppb*	<i>Data presentation</i>	online values, graphs, tables
<i>Noise at zero point (1<math>\sigma</math>)</i>	0.5 ppb*	<i>Data storage</i>	> 1 year cont. operation* measurement values, calibrations, states of operation
<i>Lagtime</i>	<1 sec	<i>Dimensions</i>	height: 178 mm (7 ") width: 450 mm (19 ") with moulding: 495 mm depth: 675 mm(26.5")
<i>Rise time (0–90%)</i>	<1 sec	<i>Weight</i>	48 kg
<i>Temperature range</i>	5–40 °C	<i>Delivery includes</i>	CLD 811 analyzer, power cable, operator's manual
<i>Humidity tolerance</i>	5–95% rel. humidity (non-condensing, ambient air and sample gas)	<i>Standard</i>	CLD 811 Heated inlet Metal converter Pressure regulation
<i>Sample flow rate</i>	1.1 l/min	<i>Options</i>	Valve manifold Analog I/O (via USB) OEM on request
<i>Input pressure</i>	600 – 1200 mbar	<i>* depending on filter setting</i>	
<i>Dry air use for O<sub>3</sub> generator</i>	internally generated (no external supply gas required)		
<i>Power required</i>	650 VA maximum (Startup) and 320 VA in operation		
<i>Supply voltage</i>	100–230 V/50–60 Hz		
<i>Interface</i>	RS 232, LAN, USB and video out		

ECO PHYSICS reserves the right to change these specifications without notice.

## Flow diagram

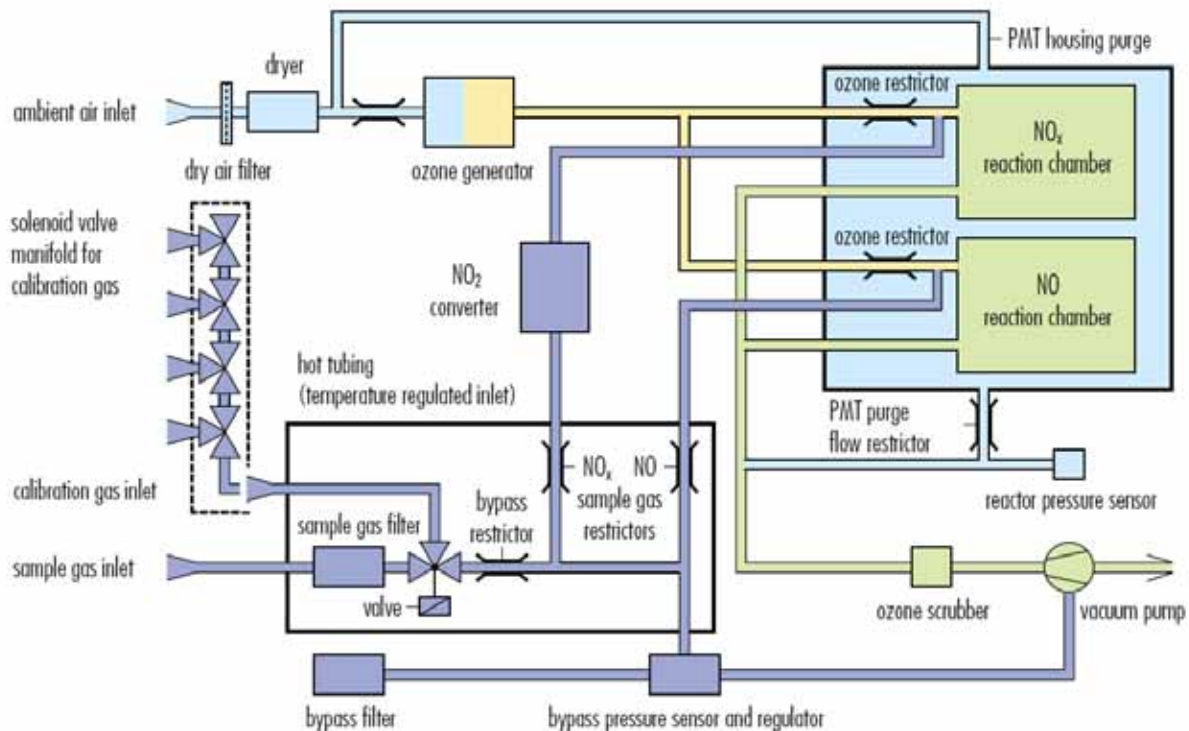

ECO PHYSICS